

Power circuit: 5V to 3.3V

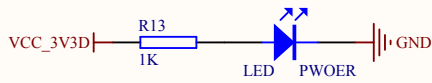

W5500 core circuit

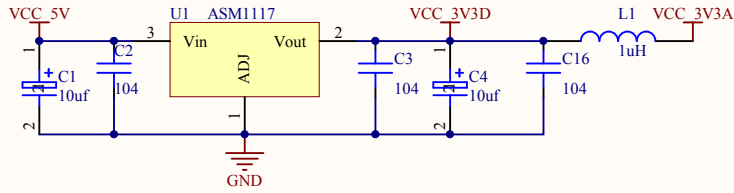
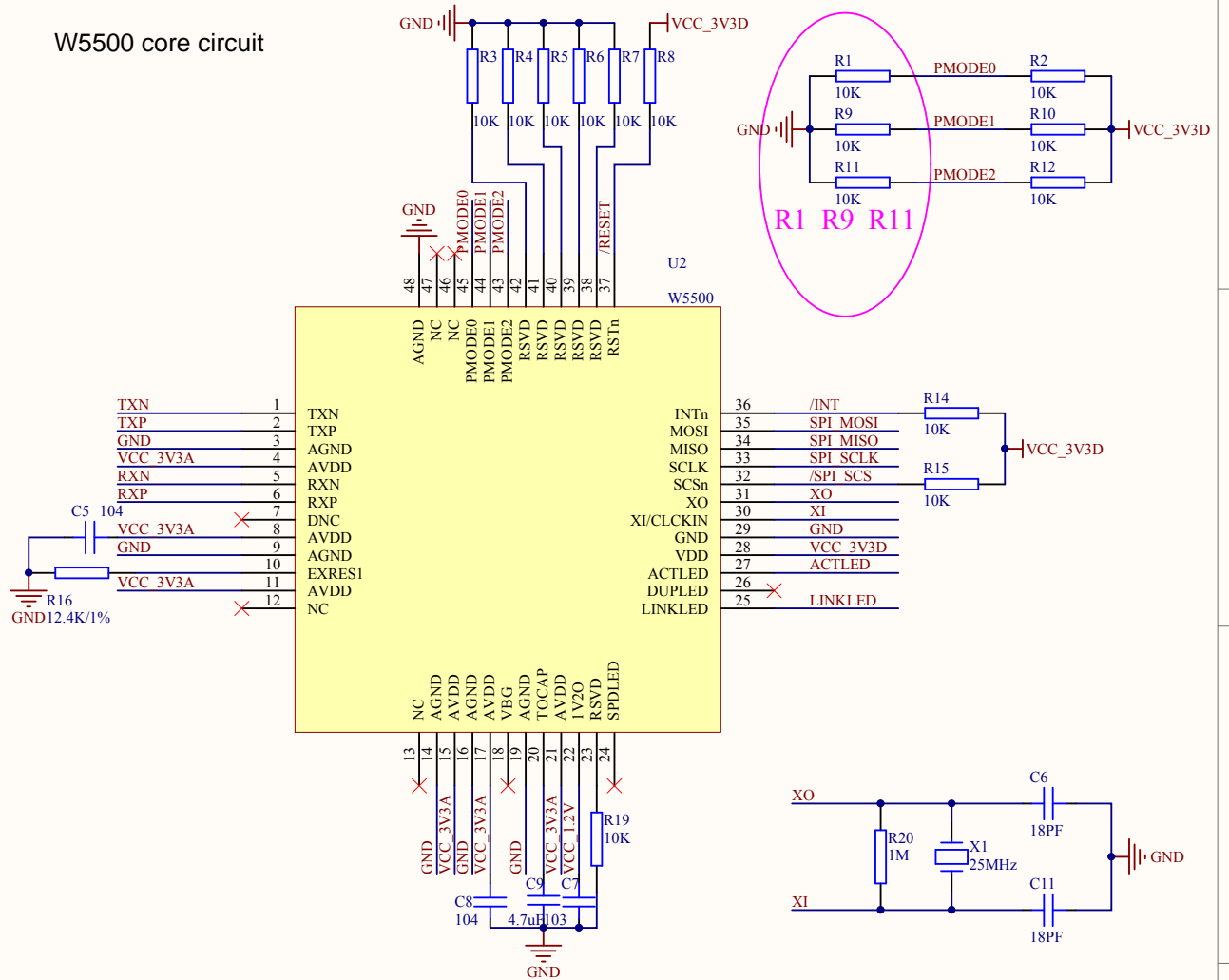

RJ45 socket circuit

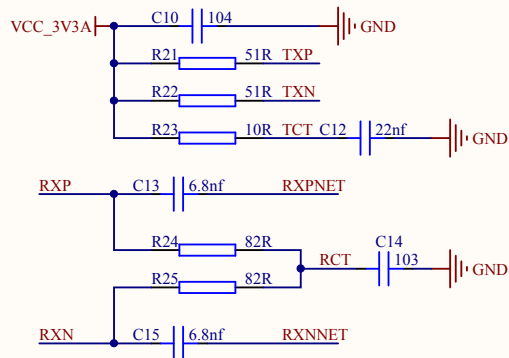
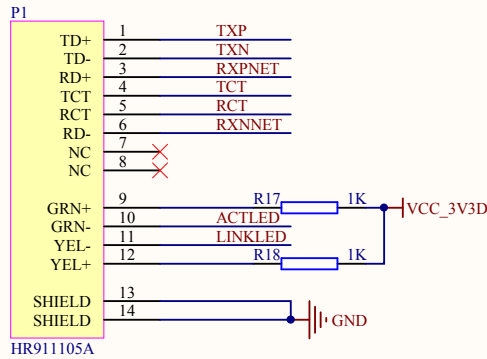

Pin header

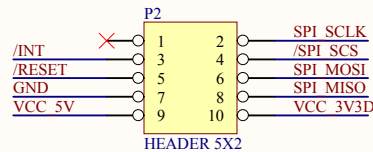

Title		
Size	Number	Revision
A4		
Date:	2014-8-10	Sheet of
File:	E:\projects\...\YIXIN W5500_V1.0.SchDoc Drawn By:	